



DC Fuse Holder

EDFH Series Fuse 1000V

Leading Manufacturer Protects Solar Power Safety

Rev3.0 2024/05/21



DC FUSE HOLDER

EDFH series DC Fuse 1000V

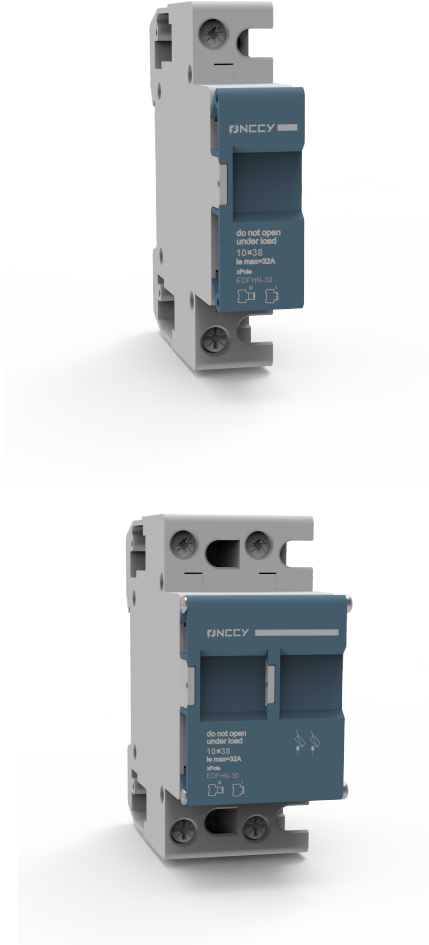

Product Application

EDFH series fuse holder is made of refractory material, and meets the standard of IEC 60947-3. The maximum rated voltage is 1000V and the maximum current is 30A. As a short circuit and over-current protector, it is widely used in the high and low voltage distribution system, control system, and electrical equipments, like distribution box and inverter.

Product Benefits

- DIN35 Rail Installation, Easy to Install
- Adjustable terminal block, Wiring firm
- Fire-retardant shell, high temperature resistance
- Flexible installation, Easy to replace

Select Code

E	D	FH	□	-	□	/	□
1	2	3	4	5	6		

Code	Name	Description
1	NCCY brand	E
2	DC	D
3	Product Code	FH: Fuse Holder
4	Rated voltage	N: 1000VDC
5	Rated current	30: 30A
6	Pole	1:1P Nil:2P

Appearance Introduction

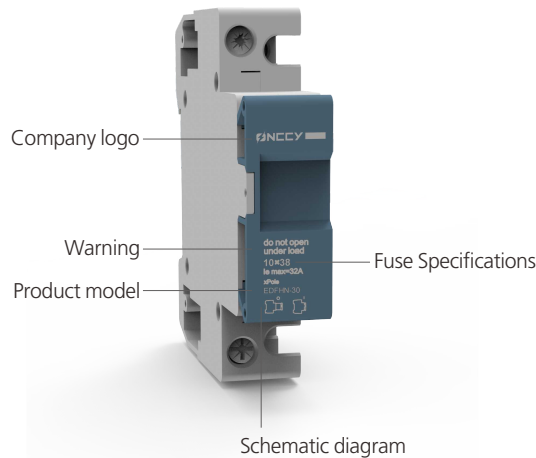

EDFH series Fuse 1000V

Technical Data

PV DC EDFH Fuse Holder Pole	1P
According to	IEC60947-3
Electrical Characteristics	
Rated Working Voltage	1000V DC
Rated Current	30A
Breaking Capacity	20kA
Max Power Dissipation	3W

Control and Indication	
Connection and Installation Wire	2.5mm ² - 6.0mm ²
Terminal Screws	M3.5
Torque	0.8~1.2N·m
Degree of Protection	IP20

Installation Environment	
Fuse Size	10x38mm
Operating Temperature Range	-30°C~+70°C
Mounting	DIN rail IEC/EN 60715
Pollution Degree	3
Relative Humidity	+20°C ≤95%, +40°C ≤50%
Installation Class	III
Weight	0.07kg Per pole

Dimensions

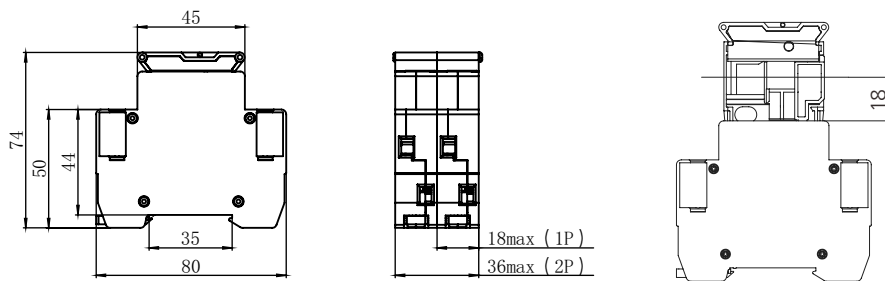

Installation

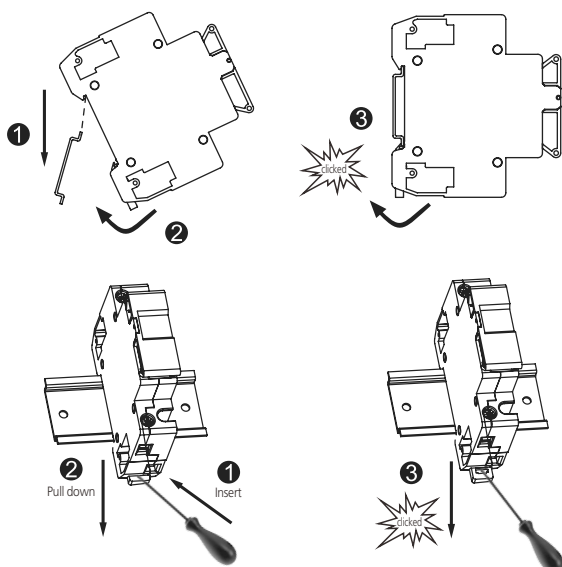

Replacement Fuse

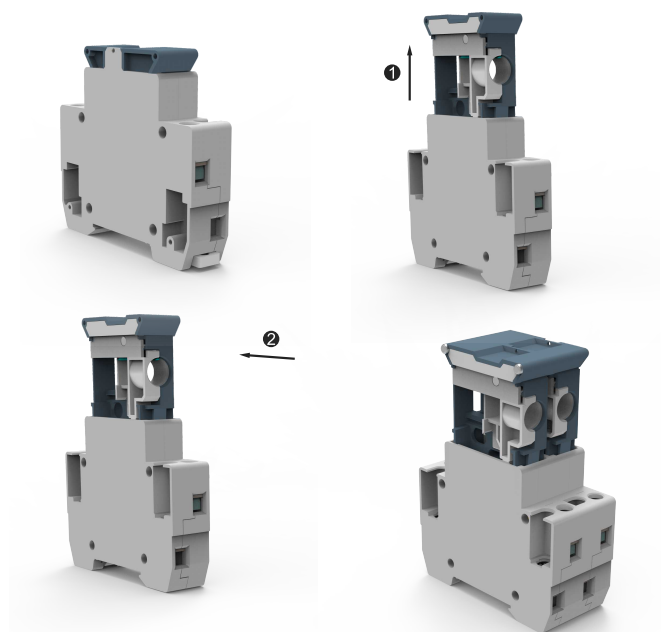

DC FUSE HOLDER

EDFH series Fuse 1000V



Product Application

EDFH series fuse holder is made of refractory material, and meets the standard of IEC 60947-3. The maximum rated voltage is 1000V and the maximum current is 32A. As a short circuit and over-current protector, it is widely used in the high and low voltage distribution system, control system, and electrical equipments, like distribution box and inverter.

Product Benefits

- Din35 Rail Installation, Easy to Install
- Adjustable terminal block, Wiring firm
- Fire-retardant shell, high temperature resistance
- Flexible installation, Easy to replace

Select Code

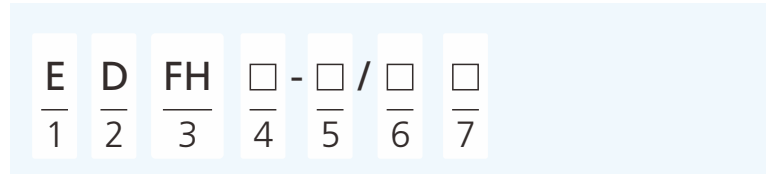

Code	Name	Description
1	brand	E
2	DC	D
3	Product Code	FH: Fuse Holder
4	Rated voltage	N: 1000VDC
5	Fuse Rated current	32: 32A
6	Pole	1: 1P
7	Light	L: with light Nil: with out light

Appearance Introduction

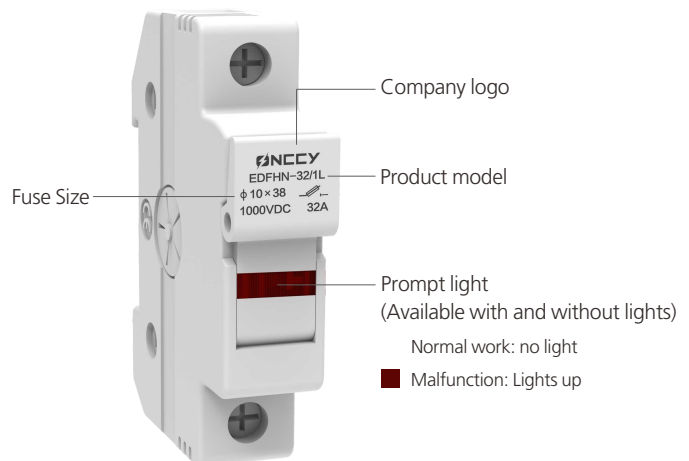

EDFH series Fuse 1000V

Technical Data

PV DC EDFH Fuse Holder Pole	1P
According to	IEC60947-3

Electrical Characteristics

Rated Working Voltage	1000V DC
Rated Current	32A
Breaking Capacity	20kA
Max Power Dissipation	3W

Control and Indication

Operating State/Fault Indication	Indicator Light OFF/Indicator Light ON
Connection and Installation Wire	1.5mm ² - 10mm ²
Terminal Screws	M3.5
Torque	0.8~1.2N·m
Degree of Protection	IP20

Installation Environment

Fuse Size	10x38mm
Operating Temperature Range	-30°C~+70°C
Mounting	DIN rail IEC/EN 60715
Pollution Degree	3
Relative Humidity	+20°C ≤95%, +40°C ≤50%
Installation Class	III
Weight	0.07kg Per pole

Dimensions

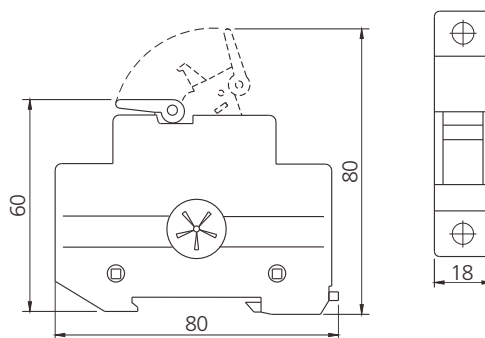

Installation

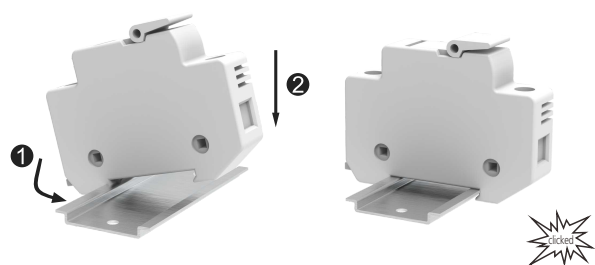

Disassemble

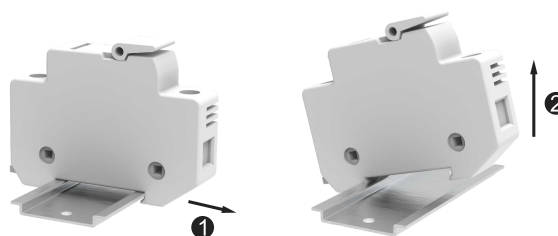

DC FUSE HOLDER

10x38mm Photovoltaic Fuses



Product Benefits

- Amps:1~32A Volts: 1000VDC Breaking Capacity:20kA @1000DC
- Compact design.Low power loss.Excellent DC performance
- Low arc voltage and low energy let-through(I2t)
- Product storage temperature: -40°C~120°C. At 40°C, the relative humidity is not more than 70%, below 30°C, not more than 80%, below 20°C, not more than 90%
- Packaging and storage temperature: -40°C~80°C. The relative humidity is not more than 90%, and there is no condensation

Altitude

- 2000 - 4500m
- Higher altitude mainly leads to insulation deterioration, heat dissipation condition deterioration and air pressure change.
 - A) The temperature rise of the fuse increases by 0.1-0.5k every 100m above sea level.
 - B) For every 100m increase in altitude, the average ambient temperature decreases by about 0.5K.
 - C) In open environment, the influence of altitude on rated current can be ignored.
 - D) When used in a closed environment, if the air temperature or box temperature does not decrease with the increase of altitude and still reaches more than 40°C, the rated current needs to be reduced. The rated current shall be reduced by 2%-5% for every 1000m increase in altitude.
- Effect of altitude on air insulation strength (breakdown strength)
 - A) Within 2000-4500m, the insulation strength decreases by 12-15% for every 1000m increase in altitude
 - B) the insulation gap between the fuse and other live structures and to the ground shall be considered by the user.

Select Code



Code	Name	Description
1	NCCY brand	E
2	DC	D
3	Product Code	F: Fuse
4	Rated size	1038: 10×38mm
5	Rated current	1A~32A

Vibration and Shock Resistance

- It has good resistance to vibration and impact, and can withstand more than 20g. Comply with the IT application environment of rail transit and the use of general motor vehicles.
- In the application environment with strong vibration, the corresponding test can be negotiated, which generally needs a long period.

Total clearing I²t

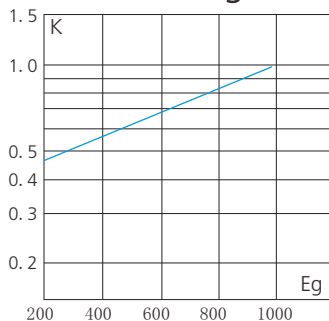

Arc Voltage

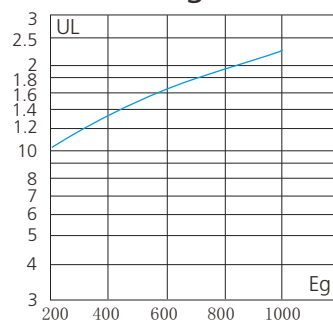

Power Losses

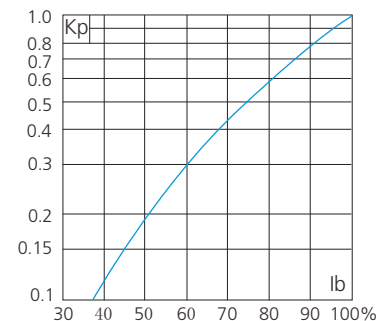

10x38mm Photovoltaic Fuses

Electrical Characteristics

Designed to: UL248-19/IEC60269-6 GB/T13539-6

Serial number	Part Number	Rated Current(A)	Energy Integrals I ² t		Watts Loss		Use bolts	Installation torque
			Pre-Arcing	Clearing at 1000V	0.8In	1In		
1	1000VDC/10X38/1A	1	0.15	0.4	0.6	1.0	-	-
2	1000VDC/10X38/2A	2	1.3	3.4	0.7	1.1	-	-
3	1000VDC/10X38/3A	3	4	12	0.8	1.3	-	-
4	1000VDC/10X38/3.5A	3.5	6.5	20	0.9	1.4	-	-
5	1000VDC/10X38/4A	4	10	28	1.1	1.4	-	-
6	1000VDC/10X38/5A	5	19	50	1.1	1.4	-	-
7	1000VDC/10X38/6A	6	28	85	1.2	1.8	-	-
8	1000VDC/10X38/8A	8	32	93	1.2	2.2	-	-
9	1000VDC/10X38/10A	10	57	100	1.3	2.3	-	-
10	1000VDC/10X38/12A	12	60	150	1.5	2.8	-	-
11	1000VDC/10X38/15A	15	149	230	1.8	3	-	-
12	1000VDC/10X38/16A	16	155	260	2.0	3.2	-	-
13	1000VDC/10X38/20A	20	230	360	2.5	3.8	-	-
14	1000VDC/10X38/25A	25	400	500	3.2	4	-	-
15	1000VDC/10X38/30A	30	550	780	3.3	4.5	-	-
16	1000VDC/10X38/32A	32	612	940	3.5	5.5	-	-

Dimension(mm)

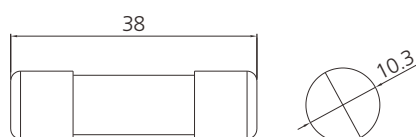

DC FUSE HOLDER

10x38mm Photovoltaic Fuses

Prospective Current In Amps RMS

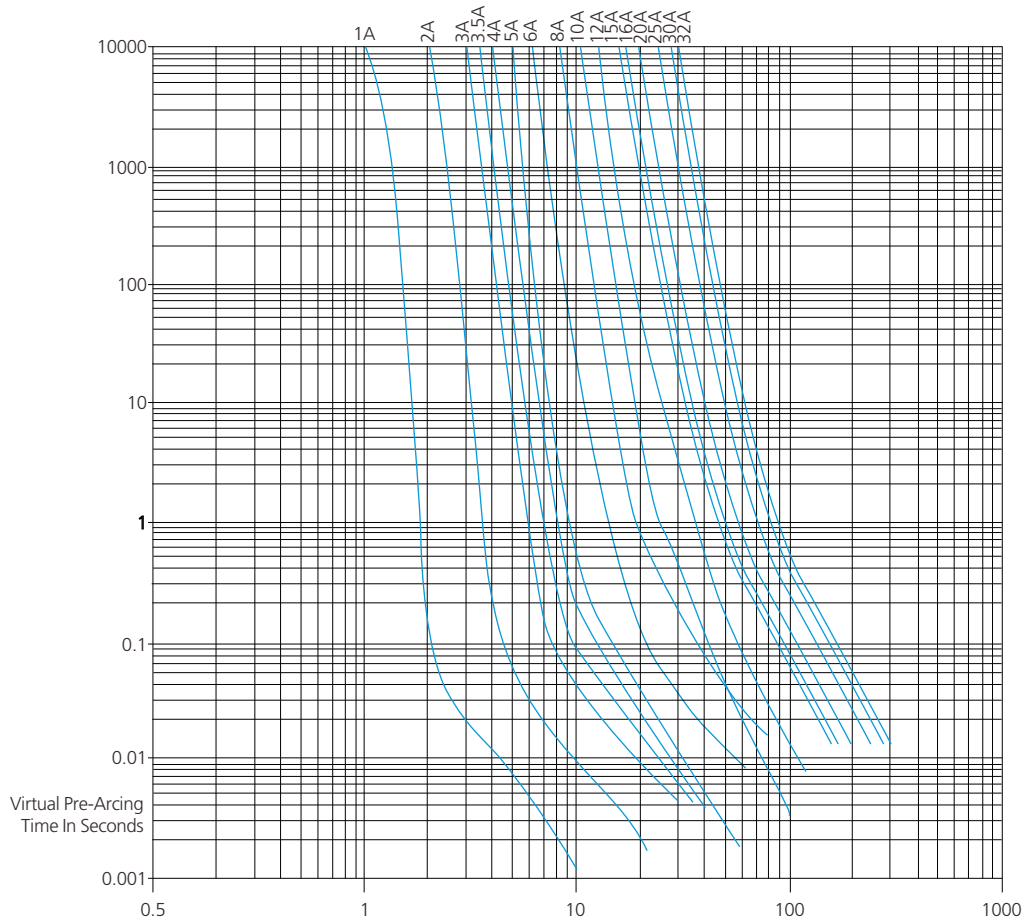

Operating conditions

- When the fuse exceeds the service conditions, some parameters may need to be corrected, and our company should be consulted.
- It is recommended that the current value of long-term through current shall not be greater than 75% of the rated current.
- Normal service conditions: -5°C ~ 40°C, allowable service conditions: -40°C ~ 80°C.
- Parameters of air temperature change: when working below -5°C, the pre arc time of low times overload current of fuse is slightly prolonged and the rated current is slightly increased. Unless the working range is above -5°C, it is generally necessary to increase the rated current of fuse
- When the fuse works above 40°C, the rated current needs additional correction, and the correction factor is - Kt

